

# High Precision Ultra-High Vacuum 6-Axis Motion Control System

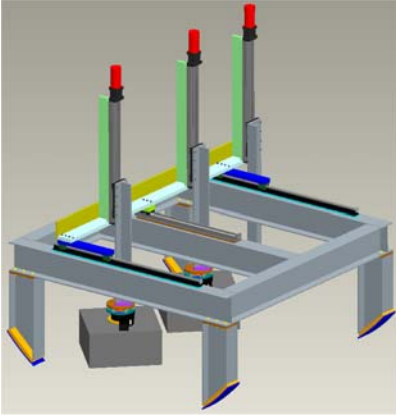

## **Application description:**

Cross Automation provided the electromechanical motion control components for the highly precise translation of multiple 350lb loads within vacuum environment of  $10^{-7}$  Torr. Very minimal outgassing permissible.

Vertical axis lifts 350lb load at rate up to 3.5 in/sec with positional repeatability of +/- 0.0002 inches.

Horizontal axis moves 1,500lb load at rate up to 4.2 in/sec with positional repeatability of +/- 0.0002 inches.

Rotary axis rotates 250lb load at angular repeatability of no more than +/- 2.8 arc seconds.

## **List of components and modifications and/or features:**

Lintech UHV Linear Stages (qty 4)

Preloaded rolled ball screw

Welded stainless steel coupling

Mechanical end of travel and home switches

Stainless radial bearings and vented hardware

Stainless linear bearings & rails, linear bearings with metal end caps.

All aluminum nickel plated

Ball screw & nut thin dense chrome plated

All bearings & ball screw lubed with Braycote 602EF.

All blind holes vented

Prior to assembly – all components cleaned with Acetone followed by IPA.

Empire Magnetics VX-U33-RTD-CBL25 NEMA34 3-Stack Stepper Motor with RTD sensor & 25ft cables

Empire Magnetics UHV Laboratory Grade Stepper Motor (qty 4)

RTD Temperature Sensor

25ft Cables

Newport UHV Precision Ground and Hardened Worm Gear Rotary Stage (qty 2)

Embedded stepper gear motor

Precision tool steel construction with double row of preloaded bearings

Renishaw UHV Angular Ring Encoder (qty 2)

Stainless steel ring with high accuracy graduations marked directly onto outer ring surface

Taper mount which corrects for eccentricity and ensures excellent accuracy

Renishaw UHV 1.0 micron Linear Encoder (qty 2)

Self-tuning adaptive electronics for high accuracy and long-term reliability

Low outgassing rates and High bake-out temperature of 120 °C

Lintech Linear Rails and Supports (qty 2)  
Shafts and linear bearings 440C stainless steel  
All mounting hardware vented  
Supports hard anodized

Parker Multi-Axis Motion Control System  
6-Axis Motion Controller with linear and circular interpolation  
Ethernet and serial communications with LabView compatibility  
Microstepping drives with 50,800 step resolution  
Necessary cables and related hardware

### **Requirements for Motion Control System:**

System will consist of three vertical drives with precision linear encoder, one horizontal drive with precision linear encoder, two rotary drives with precision rotary encoders, control and driver electronics

### **Vertical Drive:**

Stepper Motor Driven Linear actuator with 30" (76 cm) of travel with a 12" (30 cm) carriage  
Overall length of linear stage and motor will be < 55.25 inches (140 cm)  
Move 350 # (160 kg) load vertical (direction of gravity) at speeds up to 3.5 inches/sec (8.9 cm/sec)  
Incorporate 1 micron resolution encoder  
Repeatability of position to be 0.0002 inches (0.0005 cm)  
Accuracy of position +/- 0.0002 inches (+/-0.0005 cm)  
Operate in a vacuum as low as  $10^{-7}$  Torr  
Device must have no outgassing in vacuum at temperature below 104 °F (40 °C)  
Mechanical end of travel and home switches  
Stepper motor must incorporate brake which is engaged with no power  
Resistance Temperature Device (RTD) to be incorporated on motor  
Bearings, screws etc rated for minimum of  $5 \times 10^4$  cycles  
All lubrication used will meet outgassing requirements  
All blind holes to be vented  
Wiring to be flying cables properly color coded, i.e. no connectors, minimum of 20' length  
Motor, servo or stepper, must use absolute minimum power at rest to restrict motor temperature rise

### **Horizontal Drive**

Stepper Motor Driven Linear actuator with 36" (90 cm) of travel  
Move 1500 # (680 kg) load horizontal (perpendicular to gravity) at speeds up to 4.2 inches/sec (10.7 cm/sec)  
Incorporate 1 micron resolution encoder  
Repeatability of position to be 0.0002 inches (0.0005 cm)  
Accuracy of +/- 0.0002 inches (0.0005 cm)  
Operate in a vacuum as low as  $10^{-7}$  Torr  
Device must have no outgassing in vacuum at temperature below 104 °F (40 °C)  
Mechanical end of travel and home switches  
Motor must incorporate brake which is engaged with no power  
Resistance Temperature Device (RTD) to be incorporated on motor  
Bearings, screws etc rated for minimum of  $5 \times 10^4$  cycles  
All lubrication used will meet outgassing requirements  
All blind holes to be vented  
Wiring to be flying cables properly color coded, i.e. no connectors, minimum of 20' length  
Motor, servo or stepper, must use absolute minimum power at rest to restrict motor temperature rise

## **Rotary Stage**

Pro vide for 360 degree rotation

Stepper Motor driven

Normal centered load up to 300 lbs ( 135 kg)

Limit switches at +/- 170 degrees which can be disabled

"Home" switch to show "zero" position

Angular resolution of 0.001 degree

Minimum Incremental motion of 0.001 degree

Reversal Hysteresis  $\leq$  0.01 degree

Speed up to 2 degrees/second

Vacuum compatible to  $10^{-7}$  Torr

No outgassing for temperature of 104 °F (40 °C) in vacuum

Wires to be "flying" cable, properly color coded, at least 20 feet long

Central opening in rotator to be minimum of 4 inches (100 mm) diameter

Tapped Bolt Hole pattern on both ends of the rotator, 6 holes, ¼ inch (6 mm), minimum

Motor shall be less than 3 inches (75 mm) in height

Motor shall be less than 30 lbs (14 Kg) total weight

Motor, servo or stepper, must use absolute minimum power at rest to restrict motor temperature rise

## **Rotary Stage Encoder**

System accuracy  $< \pm 0.9 \times 10^{-5}$  Radians (1.9 arc second)

System repeatability  $< \pm 1.3 \times 10^{-5}$  Radians (2.8 arc second)

One (1) piece stainless 150mm diameter ring encoder with 20 micron pitch graduations

Reference interface with 1 micron resolution

Vacuum rated read head with minimum 15' cable

No outgassing in vacuum with temperature  $< 104$  °F (40 °C)

## **Control System**

The Government owns a control system composed of Parker 6K8 controller and 6 ZETRA8 motor drives for stepper motors. Any and all proposed hardware must be compatible with this existing control system.

Delivery time to be 9 weeks or less

Technical manuals/user manuals to be included with all of the hardware

**Contact RADmotion / Cross Automation at 877.573.4765 or  
solutions@RADmotion.com**